

یهیت تزریق گاز ازت

Nitrogen Ingection Filling Unit

- Main Frame: ST32 Galvanized
- Painting : Electrostatic Powder Coating RAL 7038
- Use : Transportation of Transformers without oil
- Pressure Range : Input Up to 315 bar
Output Up to 400 mbar
- Sealing Standard : DIN 16985

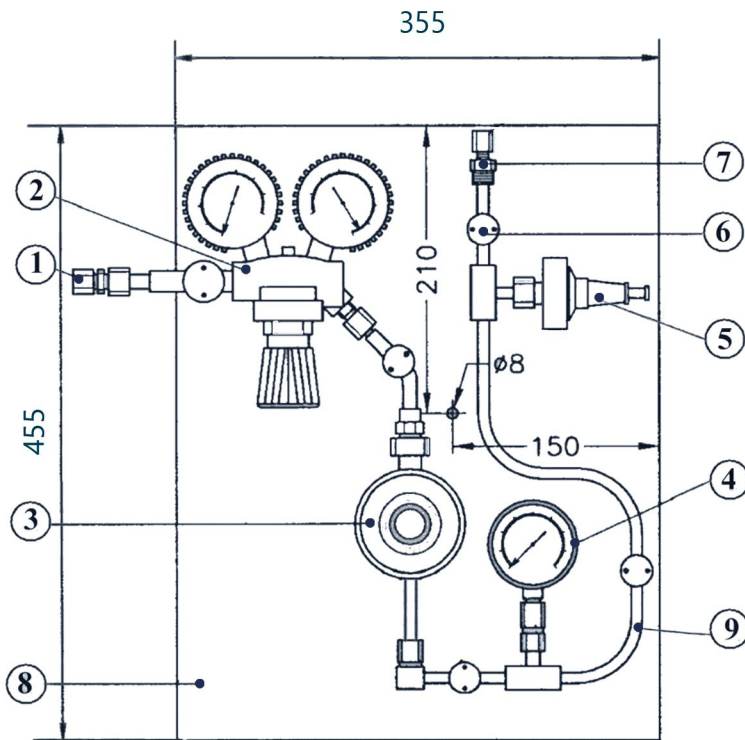

Part No.	Description	Z.I.C
1	Connection to Notrogen Source	
2	Nitrogen Gas Pressure Regulaor	
3	Gas Regulator	
4	Pressure gauge	
5	Pressure Relife Valve	
6	Holder	
7	Connection to Transformers	
8	Frame	
9	Copper pipline	

TIGHTNESS TEST:

- A) With Air Pressure Of 370 mbar , 72 hours
- B) With Nitrogen Pressure Of 150 bar , 5 min

